

# TorqueTrak Revolution Installation Guide

Tools Required: Digital multimeter, solder and soldering iron, 5/8", 9/16" and 11/16" socket wrenches, 1/8", 5/32" and 1/4" hex wrenches, and wire strippers

**CAUTION:** For successful operation there should be no metal (other than the shaft) within 1" (2.5 cm) of the Power Coil

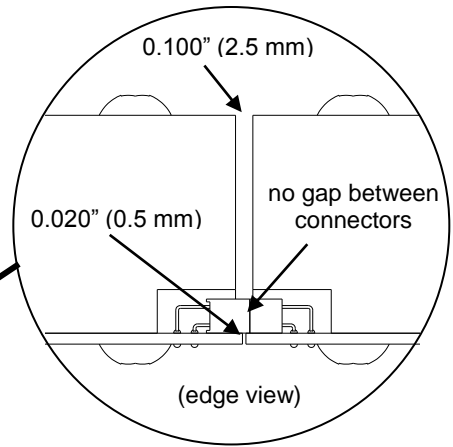

**Step 1:**

**Install Strain Gage Sensor**

- Glue gage to shaft at least 1 inch (2.5 cm) from the Rotating Collar per manufacturer's instructions.
- Do not attach Revolution lead wires to strain gage at this time.

**Step 2:**

**Secure Rotating Collar to Shaft**

- Assemble the Collar on the shaft near the gage with lead wires toward the gage.
- USE CARE WITH CONNECTORS
- Secure the Collar with bolts provided after applying antiseize compound to the threads.
- Tighten alternate bolts evenly until gap between the halves is as shown above.

Star Bridge Resistor Set

**Step 3:**

**Mount Master Control Unit**

- Mount Master Control Unit (MCU) to a mounting bracket so that the back edge of the Mounting Block is aligned with the back surface of the Collar.
- Remove the MCU cover.
- Connect power supply to Power Input connector (green) and connect to the mating terminal inside MCU.

**Step 4:**

**Install Stationary Power Coil**

- Assemble the Power Coil to the Mounting Block with screws provided.
- Verify that the Power Coil is aligned with the Collar before proceeding. Adjust the Collar or MCU position if necessary.

(shaft)

**Step 5:**

**Verify System Operation**

- Slide the Main Power switch to ON.
- After 10 seconds, verify that Main System Status and Star Bridge lights are on solid. (If Main System Status light is flashing or Star Bridge light is not on, see Troubleshooting Guide on back.)
- Connect ammeter to Torque Signal Output Terminals (1 & 2) inside MCU.
- Measure Torque Signal current (mA). Reading should be approximately 12 mA.
- Slide Remote Shunt switch inside MCU to ON. (Main System Status light will flash.)
- Measure Torque Signal current (mA). Reading should be approximately 16 mA.
- Slide Remote Shunt switch inside MCU to OFF. (Main System Status light on solid.)

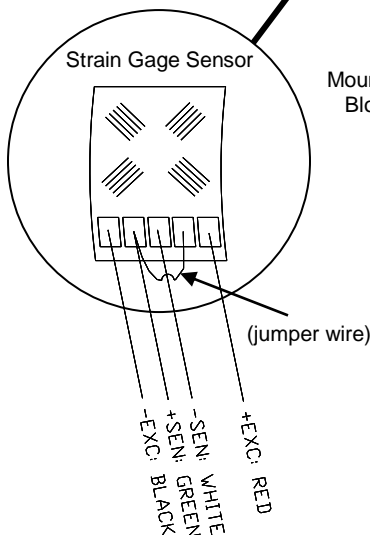

Mounting Block

Main System Status Indicator Light

**Step 6:**

**Connect Signal and Gage Wires**

- Remove star bridge from lead wires and discard.
- Solder leads from collar to gage as shown.
- Connect permanent signal leads to Signal Output connector (black) and connect to the mating terminal inside MCU.

# TorqueTrak Revolution Troubleshooting Guide

**WARNING: Supply voltage (up to 230VAC) is live inside the Master Control Unit (MCU) even when the Main Power switch is off!** Use caution when accessing internal controls.

When the TorqueTrak Revolution is first powered up, it cycles through the startup sequence, lasting 10-15 seconds. During startup mode, all of the Indicator lights flash in unison. If all system checks are positive, the Main System Status light on the outside of the control box remains on solid, and the system is ready for operation.

## Normal Operating Mode (no errors)

<i>Indicator</i>	<i>Condition</i>
Main System Status (red light outside MCU)	On solid
Stator (green light inside MCU)	On solid
Rotor (green light inside MCU)	On solid
Data (green light inside MCU)	On solid
Range (red light inside MCU)	Off

If an error is present, the Main System Status light will flash and the system will display an error code briefly (another 10-15 seconds) before the startup cycle repeats. Below are the most common error modes and potential corrective actions.

## Error Mode: Power supply voltage to system is incorrect

<i>Indicator</i>	<i>Condition</i>	<i>Suggested Corrective Action</i>
Main System Status	Fast flash (4 Hz)	1. Supply the correct voltage to the MCU (see manual for details)
Stator	Flashing (2 or 4 Hz)	

## Error Mode: Weak inductive interface

<i>Indicator</i>	<i>Condition</i>	<i>Suggested Corrective Action</i>
Main System Status	Fast flash (4 Hz)	<ol style="list-style-type: none"> <li>1. Make certain the Rotating Collar connectors are not damaged and are completely engaged</li> <li>2. Check alignment of the Rotating Collar within the Power Ring: the back surface of the Collar should align with the back edge of the Mounting Block</li> <li>3. Make certain the Power Coil is not shorted to the MCU enclosure by water or other conductive material</li> <li>4. Remove any surrounding metal other than the shaft within 1 inch (2.5 cm) of the Power Coil</li> <li>5. Verify that Rotating Coil voltage is about 120 mVAC (probe the two terminal dots on the outer surface of the Coil Boards attached to the Rotating Collar)</li> <li>6. Verify voltage is about 35 mVAC across the outer set of attachment screws to the Mounting Block</li> <li>7. Clean the mating surfaces of the Power Ring and tighten all the mounting screws</li> </ol>
Stator	On solid	
Rotor	Slow flash (2 Hz)	
Data	Off or flickering	

## Error Mode: Strain gage problem

<i>Indicator</i>	<i>Condition</i>	<i>Suggested Corrective Action</i>
Main System Status	Fast flash (4 Hz)	<ol style="list-style-type: none"> <li>1. Verify the excitation voltage to the gage is 2.5 VDC (or light on Star Bridge should be on solid when connected in place of the gage)</li> <li>2. Check solder connections and wiring to the gage</li> <li>3. Balance the gage to reduce the offset or apply a new gage</li> </ol>
Stator	On solid	
Rotor	On solid	
Data	On solid	
Range	On solid	