

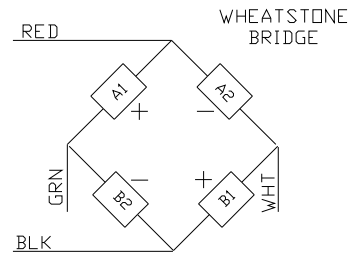

For TORQUE Measurement (Chevron pattern for full bridge, temperature compensated, bending compensated output)

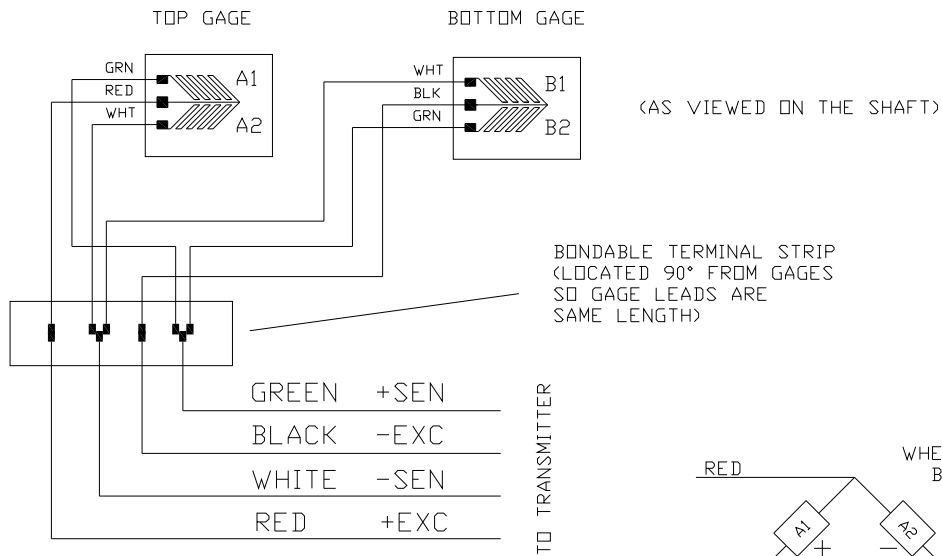
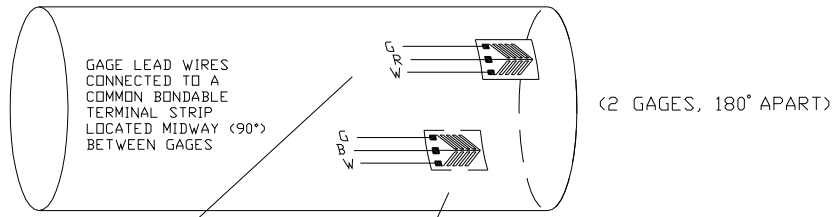

STRAIN GAGE:
VISHAY MEASUREMENTS GROUP
RALEIGH, NC
PHONE: 919-365-3800
PART # CEA-06-187UV-350
(2 REQUIRED)

NOMINAL RESISTANCE VALUES
RED TO BLACK: 350 ohms
WHITE TO GREEN: 350 ohms
ALL OTHER TESTS: 262.5 ohms

REVISION: 1

Leading Technology in Rotary Torque and Temperature Transmitters